



Ex-proof's our business

FL SERIES EXPLOSION-PROOF FLOODLIGHTS

Certificate : INSEMEX-OEC.ATEX.2012.3.0008X

CE 1809  II 2 G Ex d e IIB T3

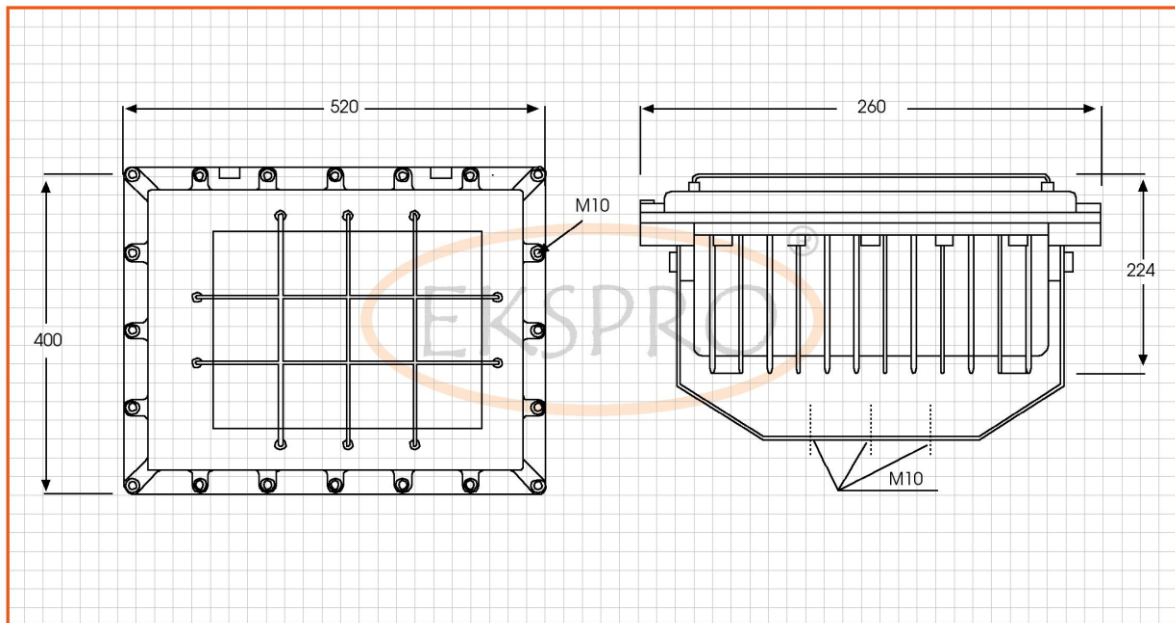

APPLICATIONS

FL series floodlight are used to illuminate Storage tanks, outdoor process areas, parking areas which are hazardous due to the presence of flammable vapours or gases or dampness or corrosion are present. In petroleum refineries, chemical and petrochemical plants and other process industry facilities where similar hazard exist.

- Max. Power : 400 W
- Operating Voltage : 240 VAC
- Lamp types : High pressure Sodium, Mercury vapour, metal halide and halogen.



Ex-proof's our business

FL SERIES EXPLOSION-PROOF FLOODLIGHTS

Certificate : INSEMEX-OEC.ATEX.2012.3.0008X

CE 1809  II 2 G Ex d e IIB T3

APPLICABLE STANDARTS

EN 60079-0 ,EN 60079-1

MATERIAL

Aluminium – Etial 171
Copper Content < 0.01 %
Device Colour: RAL7040

THREAD SIZE and TYPE

3/4" Withworth pipe thread TS61

Options

Tapered thread ANSI B2 1NPT
ISO 7/1R
PG thread DIN 40430

PROTECTION TYPE

IP66